

CH120 CH120A

300 CUBIC METERS SCENT DIFFUSER MACHINE

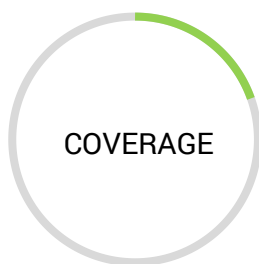

COVERAGE

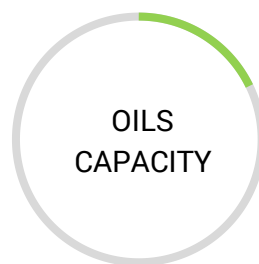

OILS
CAPACITY

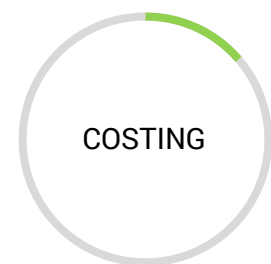

COSTING



300 CBM coverage



With Manual control and Wi-Fi Control 2 versions



19 Intensity Setting Options



With Security lock



150ml Aluminum Oil Bottle



Long lifespan air pump

Accessory

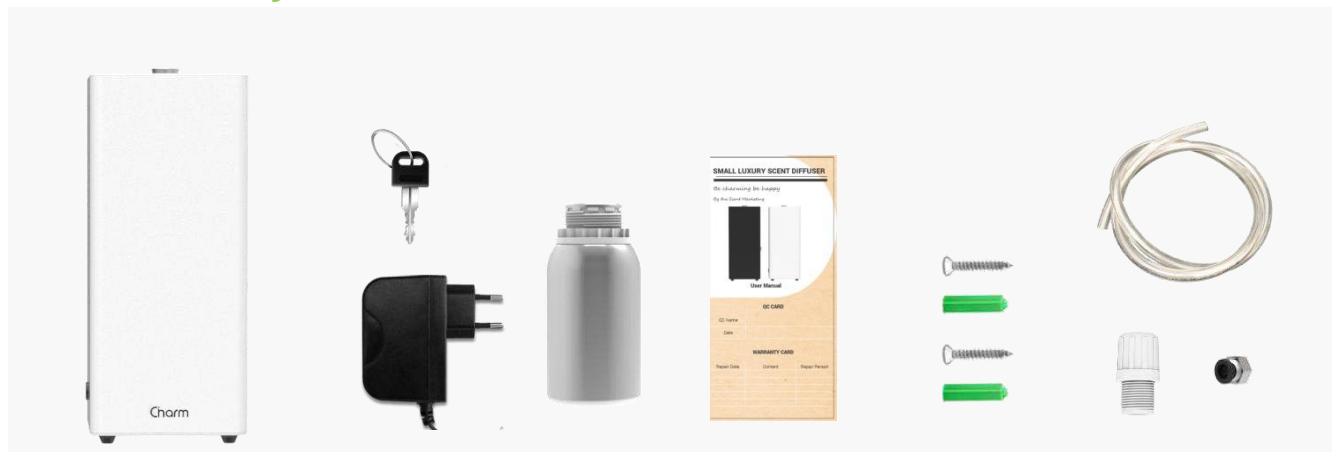

Charm Aroma
Diffuser

Keys+ AC
Power

Empty
150ml Oil
Bottle

User
Manual

Screws

Air Tube+ Spare
Atomizer Core+
Connector

Specifications

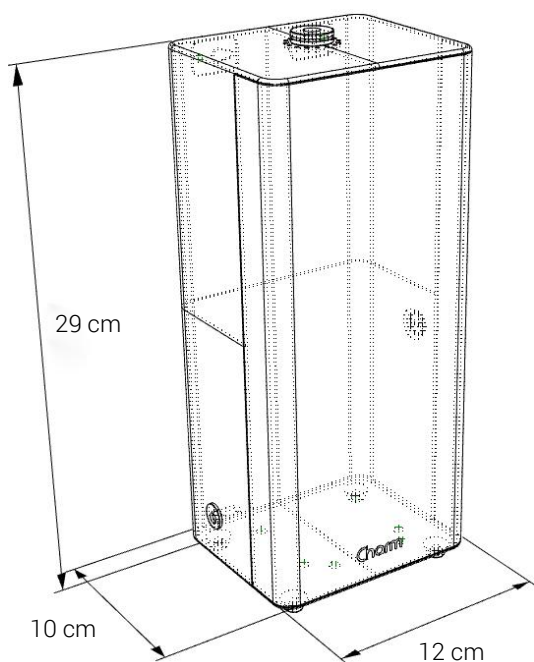

Model No.	CH120
Shell Material	Metal with powder coated finishing
Color	White , Black
Dimension	290H X 120W X 100D mm
Net Weight	1.95kg
Standard Packing	8 Pieces/ Master Carton
Power Supply	DC12V/ 5W
Coverage	up to 300m3; up to 100 m ² ; up to 1000 ft ²
Installation Way	Connect FCU /Wall Mounted / Stand-alone
Essential Oil Bottle Capacity	150ml in Aluminum Material
Essential Oil Consumption	0.05ml to 0.95 ml per hour ±5%
Atomizer Material	Aluminum Alloy
Memory Battery	3V
Noise Level	< 38dba

Applications



4S Shop



Bar



Shopping Mall



Hotel



KTV



Bank



Store



Restaurant



Airport



Salon