



CH123

5000 CUBIC METERS SCENT DIFFUSER

COVERAGE

OILS
CAPACITY

COSTING



Large Coverage 5000 Cubic Meters



Programmable Working Time 24H/7 days



19 Intensity Setting Options



With Security lock



Manual Control and Wi-Fi Control 2 Versions



Long lifespan air pump

Accessory

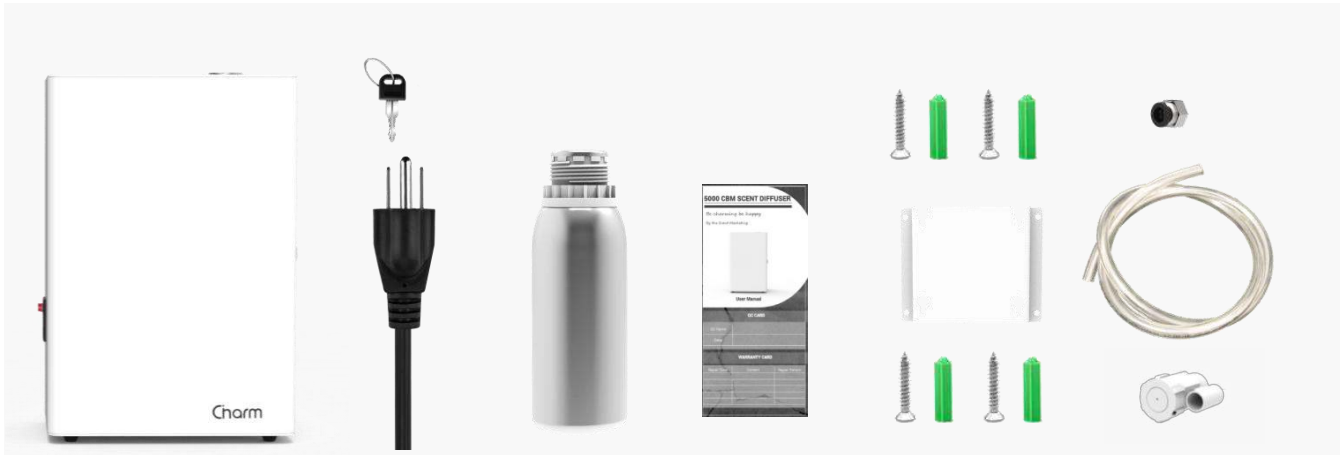

Charm Aroma Diffuser

Keys+ AC Power Adapter

1000ml Empty Oil Bottle

User Manual

Screws + Wall Mounted Panel

Connector+ Air Tubes+ Spare

Specifications

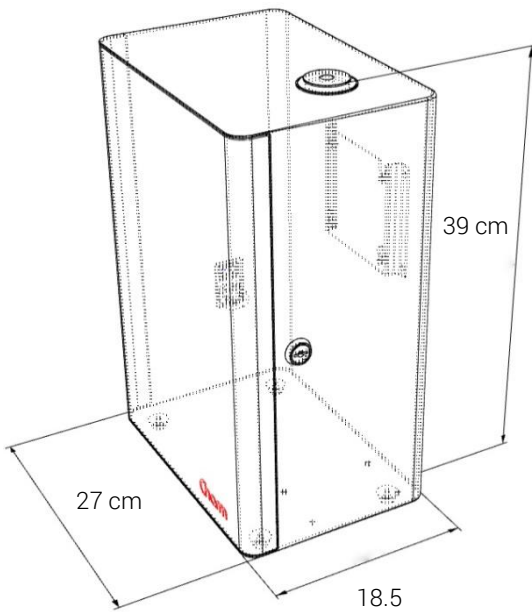

Model No.	CH123
Shell Material	Anticorrosion Metal
Color	White , Black
Dimension	390H X 270W X 185D mm
Net Weight	9kg
Standard Packing	4 Piece / Master Carton
Power Supply	110-220V/ 26W
Coverage	5000 m3 ; 1600 m ² ; 16000 ft ²
Installation Way	Connect HVAC /Wall Mounted / Standalone
Essential Oil Bottle Capacity	1000ml
Essential Oil Consumption	0.4ml ~ 7.6 ml /H±5%
Noise Level	< 50dba

Applications



4S Shop



Bar



Shopping Mall



Hotel



KTV



Bank



Store



Restaurant



Airport



Salon