



CH128

1200 CUBIC METERS SCENT DIFFUSER MACHINE



COVERAGE

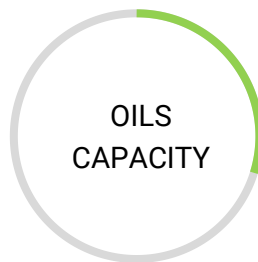

OILS
CAPACITY



COSTING



1200 CBM coverage with inner fan



Programmable Working Time 24H/7 days



19 Intensity Setting Options



With Security lock



Manual Control and WI-FI Control 2 Versions



Long lifespan air pump

Accessory



Charm Aroma
Diffuser

Keys+
Adapter

Empty
500ml Oil
Bottle

User
Manual

Screw Sets

Air Tube+ Spare
Nozzle +
Connector

Specifications

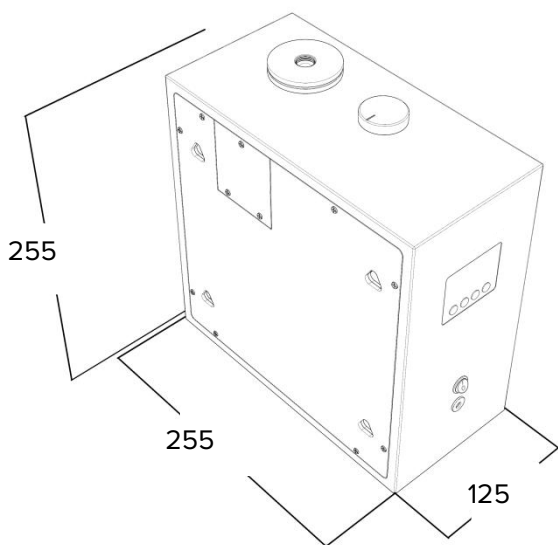

Model No.	CH128
Shell Material	Metal with powder coated finishing
Color	White , Black
Dimension	255*255*125mm
Net Weight	4kg
MOQ	4 Pieces
Power Supply	DC12V8W
Coverage (Maximum)	1200 m3 ; 400 m ² ; 4000 ft ²
Installation Way	Connect HVAC /Wall Mounted / Stand-alone
Essential Oil Bottle Capacity	500ml in Aluminum Material
Essential Oil Consumption	0.09ml to 1.66 ml per hour ± 5%
Atomizer Material	Aluminum Alloy
Memory Battery	3V
Noise Level	< 42dba

Applications



4S Shop



Bar



Shopping Mall



Hotel



KTV



Bank



Store



Restaurant



Airport



Salon